

PT001XX-001

Pressure Transducer Wireless Measurement Sensor

Features

- Pressure range: 0-3600 psi (250 bar)
- Pressure resolution: 1 psi. (0.069 bar)
- Pressure accuracy (typ): 5 psi. (0.345 bar)
- Measurement is optimized for crane movements.
- The pressure transducers can be installed directly on the boom hoist cylinder or at a remote location.
- Pressure transducer with 6.5 ft. (2 m) of cable to mount transmitter away from
- Integrated pressure spike protection.
- Radio range with line of sight: 1300 ft. (400 m)
- Operates with two 'D' cell batteries lithium 3.6V.
- 1 to 3 years battery life for typical applications
- ISM license free radio; wavelength and modulation optimized for radio communication in industrial environments.
- Temperature range: -40°C to 65°C (-40°F to 150°F)
- Temperature compensated
- Potted electronics for increased protection

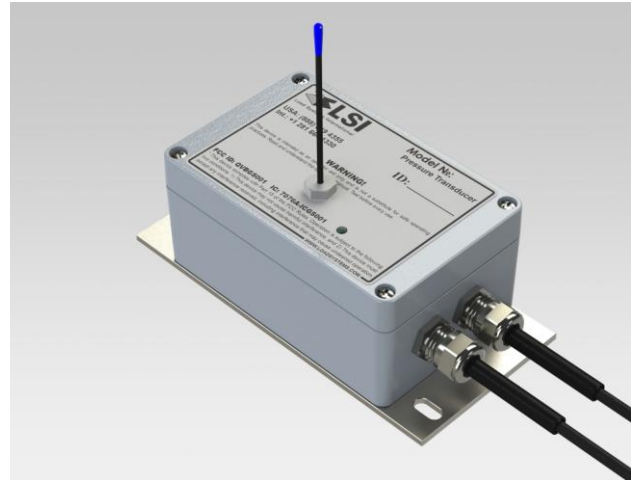

Pressure sensor transmitter p/n PT001XX-001

Applications

- Measurement of crane boom hoist cylinder pressure. Monitors pressure on both sides of cylinder.
- Designed to be utilized as part of the LSI Load Moment Indicator (LMI) system.
- Crane can have multiple boom hoist cylinders, but must have an equalizer hose ensuring holding valve on each cylinder sees the same pressure.

General Description

The pressure sensor was designed to be an integral part of the LSI load moment indicator system.

The pressure sensor has 6.5 ft. (2 m) of cable. The cable allows the transmitter to be mounted to a flat, safe surface separate from the installation location of the pressure transducers.

The transmitter box houses the batteries and the radio transmitter.



Pressure transducers

Table of Contents

Features	1
Applications	1
General Description	1
Table of Contents	2
Ordering Information	2
Specifications	3
Absolute Maximum Ratings	3
Certifications	3
Dimensions and Installation	4

Ordering Information

Model	Description
PT001XX-001	Pressure transmitter with sensors for rod (3.6KPSI) and piston (3.6KPSI) pressures
TA011	Replacement sensor antenna

PT001XX-001

Specifications

Parameter	Test Condition	Min	Typ	Max	Unit
Pressure					
Range		0		3600	PSI
Resolution			1.0		PSI
Accuracy		15	5		PSI
Fitting			1/4 NPT		Inch
Radio Power					
		0.0003	0.0007	0.001	W
		-2	-1	0	dBm
Radio Frequency					
North American version	PT00100-xxx	902	916	928	MHz
European version	PT00120-xxx	868	869	870	MHz
Battery life					
	Two 'D' cell battery life depends on usage	12	24	36	Month
Other					
Weight			2.5 (1.140)		lb (kg)

Absolute Maximum Ratings

Parameter	Test Condition	Min	Typ	Max	Unit
Temperature range	Operating	-40		+65	°C
		-40		+150	°F

Certifications

FCC/IC
CE

Dimensions and Installation

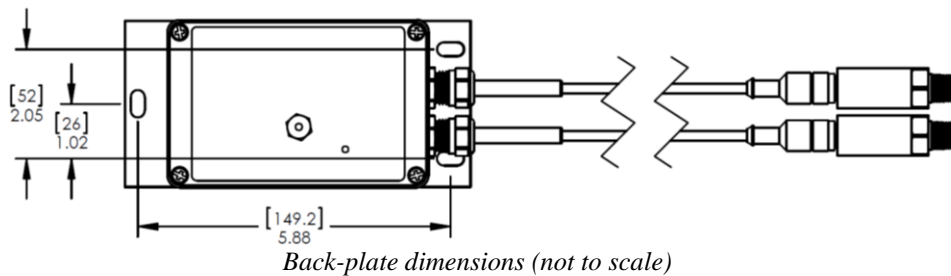
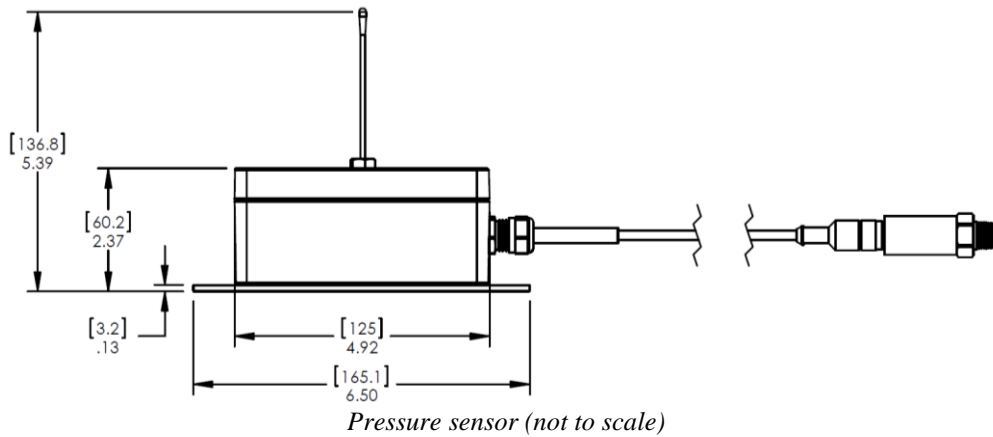

Units are in inches [millimeters]

Installing the transmitter

The transmitter comes attached to a mount plate. The mount plate can be welded, attached with threaded studs, or bolted to the machine. It is necessary to remove the mount plate from the transmitter if this plate is to be welded. Ensure 6 inches of clearance of metal around the transmitter antenna, to ensure good reception in the cab. Locate the transmitter where there is a minimal amount of objects between the transmitter and display.

Installing the piston side transducer

The pressure transducer that monitors the pressure on the boom lift cylinder piston should tie into the hydraulics between the holding valve and the cylinder piston. The hydraulic block mounted to the cylinder will most often have a port to monitor this pressure. Here, the transducer or a hose to a remote location can be applied.

For machines with more than one boom-lift cylinder, this will be occupied by a hose that ensures there is identical pressure in both cylinders. In this case, a tee would need to be added for the pressure transducer.

Installing the rod side transducer

The pressure transducer that monitors the back (rod) side of the piston can tie in anywhere along the return line from the cylinder, but is best to locate it near the other transducer. This will simplify running the cables between the transmitter and both transducers. A tee will need to be used to tie into the return line.

Routing the cables

The cables should be routed to the transducers and secured to prevent damage the sensor itself or other parts of the machine. The routing should be such that any movement of the crane will not result in the cable being pulled or prone to snag on anything during crane functions.

The transducers and transmitter should be installed where they will not be prone to damage or cause a safety hazard when working around them. For further information, see the LMI System- Load Moment Indicator calibration guide.