

Rugged, field replaceable antenna
Part number: TA011

Two way radio technology

Heavy duty construction

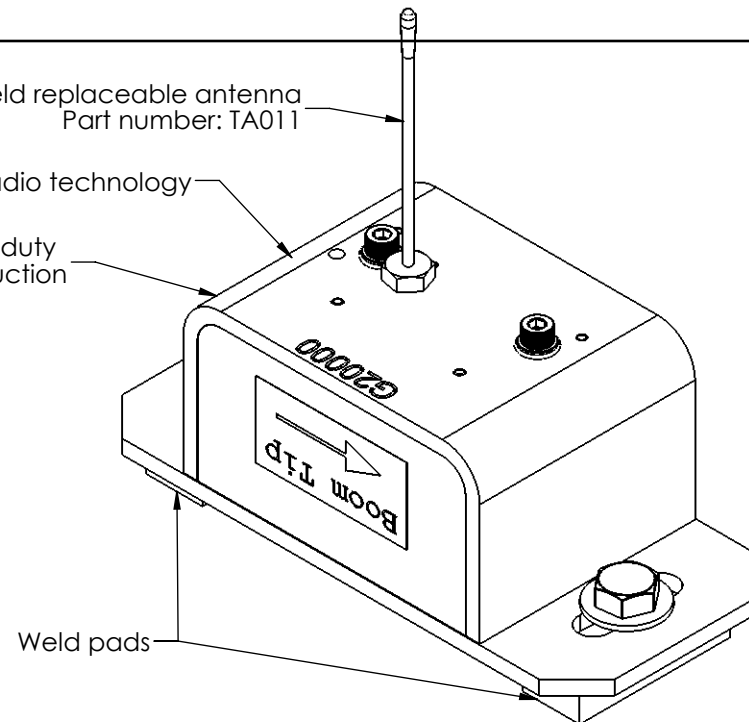

Installation: either left or right side of boom, the angle sensor will automatically detect the side on which it is installed.

Range	-180.0° to 130°, 0° being horizontal
Resolution	+/- 0.1°
Repeatability	+/- 0.2°
Accuracy	+/- 0.5° max. (typical +/- 0.2°)
Battery	1 "D-Cell" Lithium, or alkaline
Estimated Battery Life*	Lithium: 2 years, Alkaline: 8 months
Operating temperature	-31 to 185 °F
Radio Frequency Band	900 MHz standard - European Community's 868 MHz as an option
Radio Power	15 dBm
Material	Stainless Steel
Weight	4 lb

All dimensions are in inches
The information in this document is subject to change without notice

*Battery life estimated for standard product only, using factory specified batteries correctly installed, operating for 32 hours per week. Individual results may vary with intensity of use, environmental conditions and other factors.

PROPRIETARY AND CONFIDENTIAL

THE INFORMATION CONTAINED IN THIS DRAWING IS THE SOLE PROPERTY OF LOAD SYSTEMS INTERNATIONAL. ANY REPRODUCTION IN PART OR AS A WHOLE WITHOUT THE WRITTEN PERMISSION OF LOAD SYSTEMS INTERNATIONAL IS PROHIBITED.



Load Systems International

www.loadsystems.com

PART NO: **GS010-01** DWG NO: **DS-GS010-01** REV: **6**

DESCRIPTION: **Wireless Boom Angle Sensor**

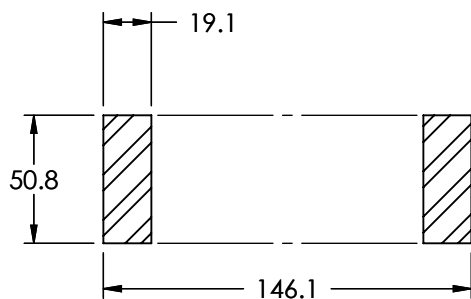
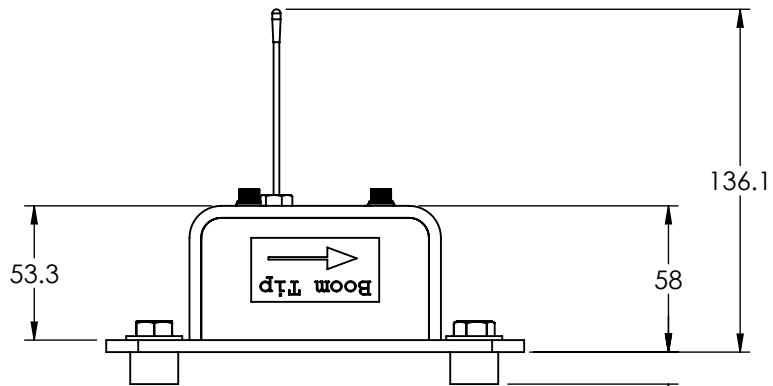
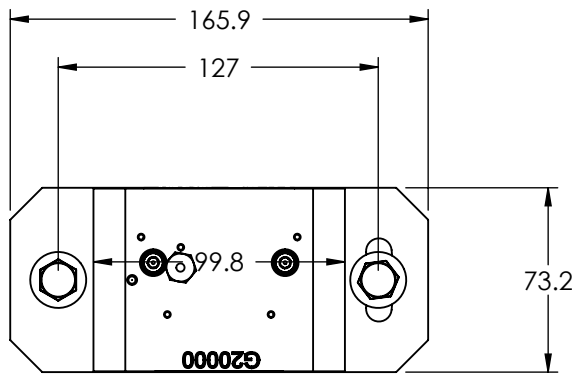

Weld pads footprint

Rugged, field replaceable antenna
Part number: TA011

Two way radio technology

Heavy duty construction

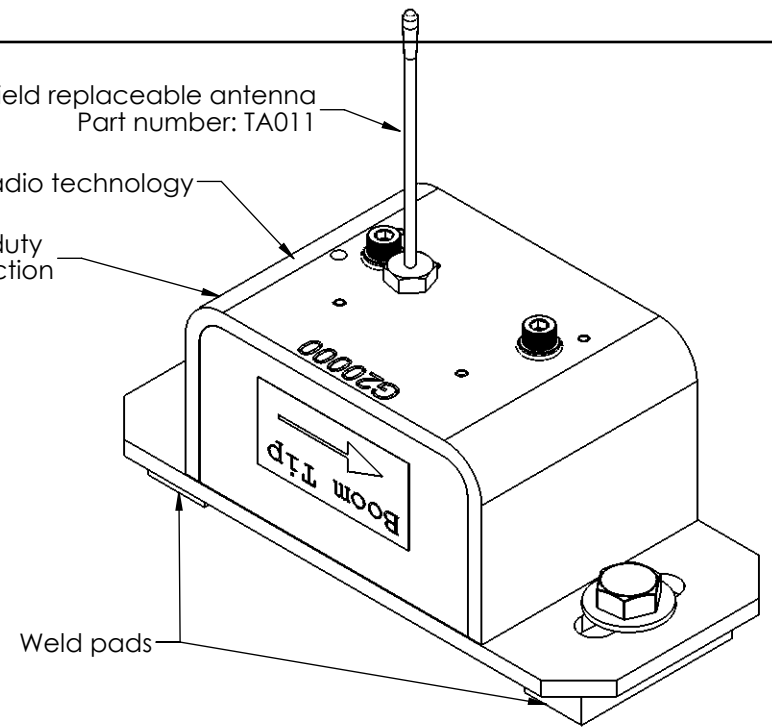

Installation: either left or right side of boom, the angle sensor will automatically detect the side on which it is installed.

Range	-180.0° to 130°, 0° being horizontal
Resolution	+/- 0.1°
Repeatability	+/- 0.2°
Accuracy	+/- 0.5° max. (typical +/- 0.2°)
Battery	1 "D-Cell" Lithium, or alkaline
Estimated Battery Life*	Lithium: 2 years, Alkaline: 8 months
Operating temperature	-35 to +85 °C
Radio Frequency Band	900 MHz standard - European Community's 868 MHz as an option
Radio Power	15 dBm
Material	Stainless Steel
Weight	1.8 kg

All dimensions are in mm
The information in this document is subject to change without notice

*Battery life estimated for standard product only, using factory specified batteries correctly installed, operating for 32 hours per week. Individual results may vary with intensity of use, environmental conditions and other factors.

PROPRIETARY AND CONFIDENTIAL

THE INFORMATION CONTAINED IN THIS DRAWING IS THE SOLE PROPERTY OF LOAD SYSTEMS INTERNATIONAL. ANY REPRODUCTION IN PART OR AS A WHOLE WITHOUT THE WRITTEN PERMISSION OF LOAD SYSTEMS INTERNATIONAL IS PROHIBITED.



PART NO: **GS010-01** DWG NO: **DS-GS010-01** REV: **6**

DESCRIPTION: **Wireless Boom Angle Sensor**

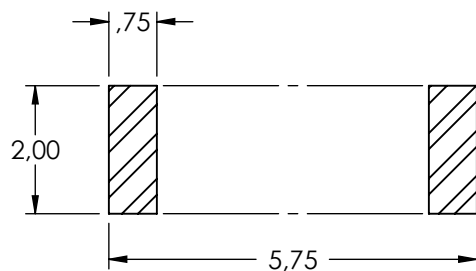
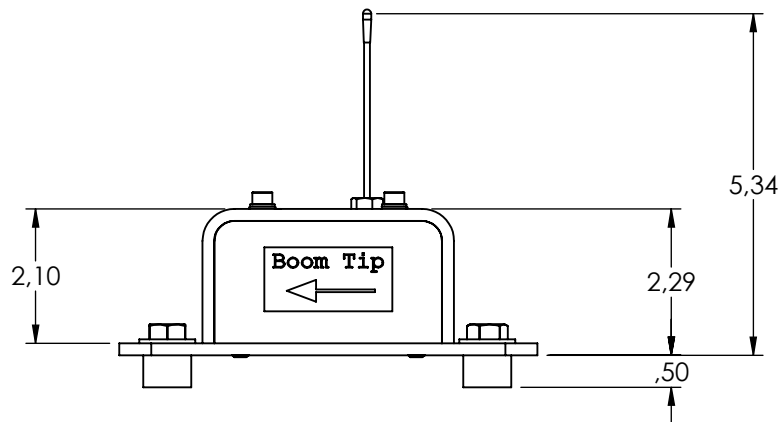
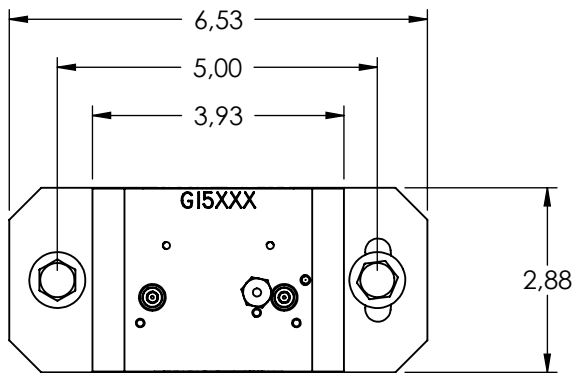

Weld pads footprint

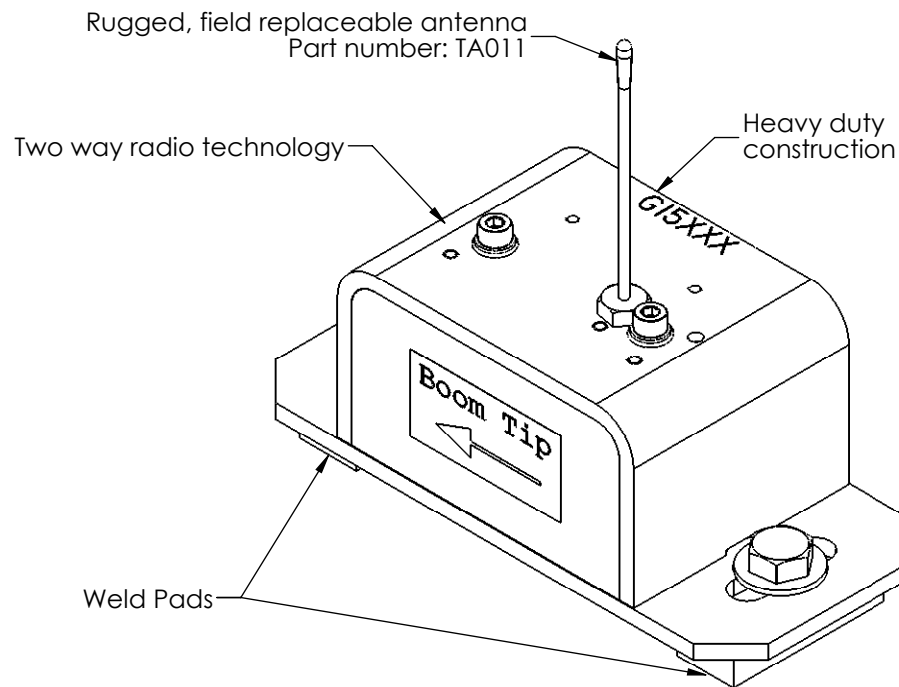

For knuckle boom or other special applications.

Range	0° to 359.9°
Resolution	+/- 0.1°
Repeatability	+/- 0.2°
Accuracy	+/- 0.5° max. (typical +/- 0.2°)
Battery	1 "D-Cell" Lithium, or alkaline
Estimated Battery Life*	Lithium: 2 years, Alkaline: 8 months
Operating temperature	-31 to 185 °F
Radio Frequency Band	900 MHz standard - European Community's 868 MHz as an option
Radio Power	15 dBm
Material	Stainless Steel
Weight	4 lb

All dimensions are in inches
The information in this document is subject to change without notice

*Battery life estimated for standard product only, using factory specified batteries correctly installed, operating for 32 hours per week. Individual results may vary with intensity of use, environmental conditions and other factors.

PROPRIETARY AND CONFIDENTIAL

THE INFORMATION CONTAINED IN THIS DRAWING IS THE SOLE PROPERTY OF LOAD SYSTEMS INTERNATIONAL. ANY REPRODUCTION IN PART OR AS A WHOLE WITHOUT THE WRITTEN PERMISSION OF LOAD SYSTEMS INTERNATIONAL IS PROHIBITED.



Load Systems International

www.loadsystems.com

PART NO: **GS010-02** DWG NO: **DS-GS010-02** REV: **4**

DESCRIPTION: **Wireless 360° Angle Sensor**

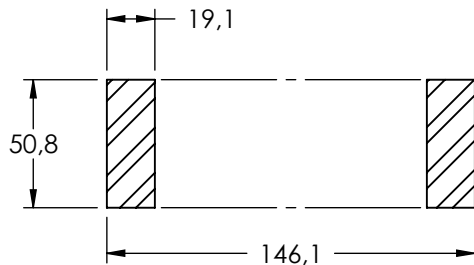
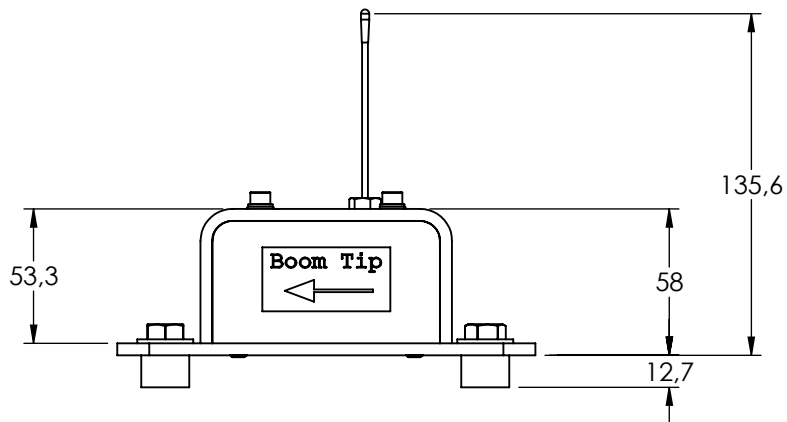
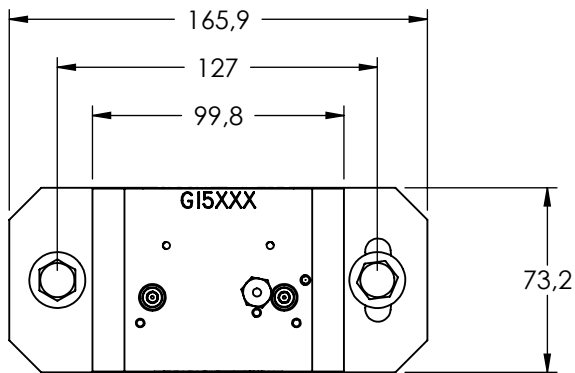

Weld pads footprint

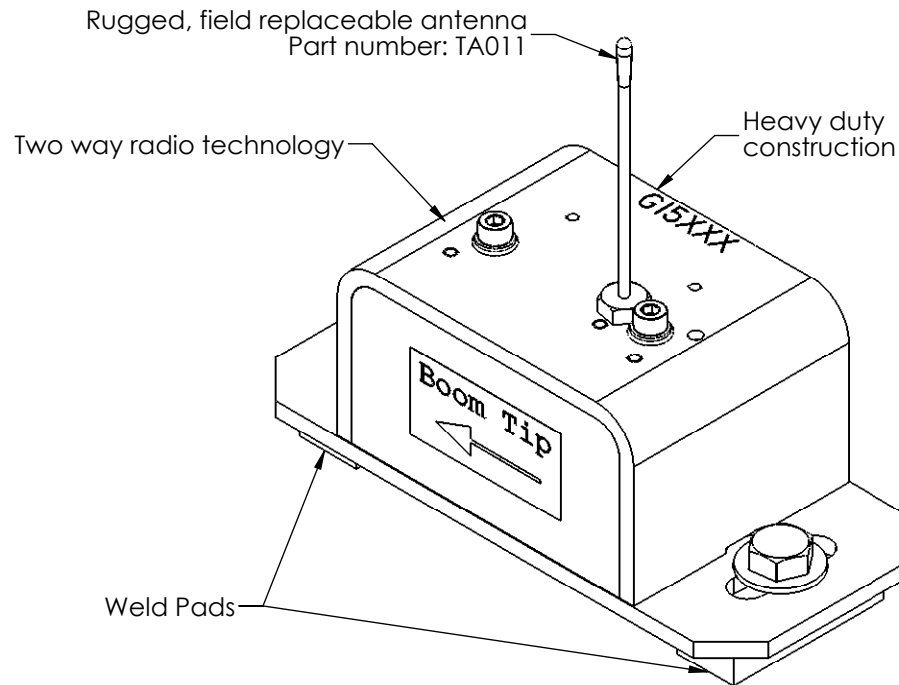

For knuckle boom or other special applications.

Range	0° to 359.9°
Resolution	+/- 0.1°
Repeatability	+/- 0.2°
Accuracy	+/- 0.5° max. (typical +/- 0.2°)
Battery	1 "D-Cell" Lithium, or alkaline
Estimated Battery Life*	Lithium: 2 years, Alkaline: 8 months
Operating temperature	-35 to +85 °C
Radio Frequency Band	900 MHz standard - European Community's 868 MHz as an option
Radio Power	15 dBm
Material	Stainless Steel
Weight	1.8 kg

All dimensions are in mm
The information in this document is subject to change without notice

*Battery life estimated for standard product only, using factory specified batteries correctly installed, operating for 32 hours per week. Individual results may vary with intensity of use, environmental conditions and other factors.

PROPRIETARY AND CONFIDENTIAL

THE INFORMATION CONTAINED IN THIS DRAWING IS THE SOLE PROPERTY OF LOAD SYSTEMS INTERNATIONAL. ANY REPRODUCTION IN PART OR AS A WHOLE WITHOUT THE WRITTEN PERMISSION OF LOAD SYSTEMS INTERNATIONAL IS PROHIBITED.



Load Systems International

www.loadsystems.com

PART NO: **GS010-02** DWG NO: **DS-GS010-02** REV: **4**

DESCRIPTION: **Wireless 360° Angle Sensor**

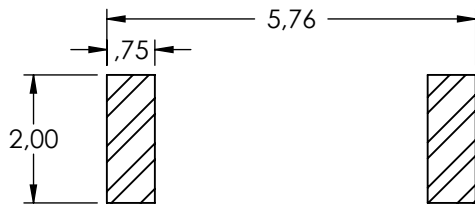
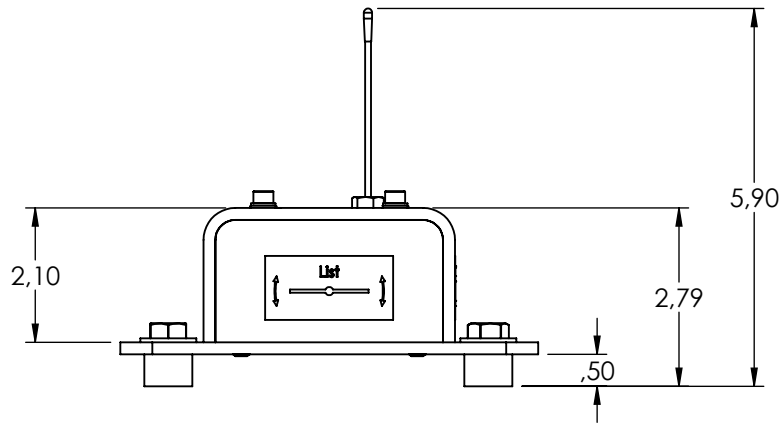
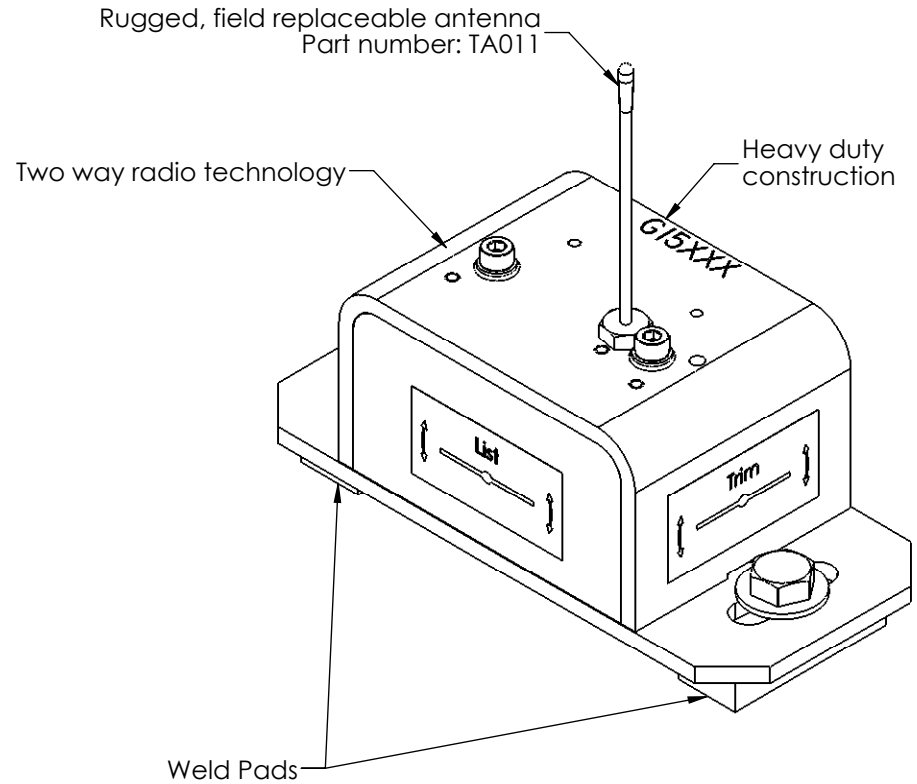
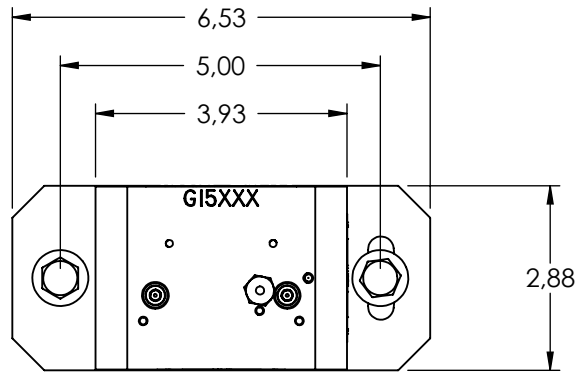

Weld pads footprint

Range	-15° to 15°
Resolution	+/- 0.1°
Repeatability	+/- 0.2°
Accuracy	+/- 0.5° max. (typical +/- 0.2°)
Battery	1 "D-Cell" Lithium, or alkaline
Estimated Battery Life*	Lithium: 2 years, Alkaline: 8 months
Operating temperature	-31 to 185 °F
Radio Frequency Band	900 MHz standard - European Community's 868 MHz as an option
Radio Power	15 dBm
Material	Stainless Steel
Weight	4 lb

All dimensions are in inches
The information in this document is subject to change without notice

*Battery life estimated for standard product only, using factory specified batteries correctly installed, operating for 32 hours per week. Individual results may vary with intensity of use, environmental conditions and other factors.

PROPRIETARY AND CONFIDENTIAL

THE INFORMATION CONTAINED IN THIS DRAWING IS THE SOLE PROPERTY OF LOAD SYSTEMS INTERNATIONAL. ANY REPRODUCTION IN PART OR AS A WHOLE WITHOUT THE WRITTEN PERMISSION OF LOAD SYSTEMS INTERNATIONAL IS PROHIBITED.



PART NO: **GS010-03** DWG NO: **DS-GS010-03** REV: **8**

DESCRIPTION: **Wireless List and Trim Angle Sensor**

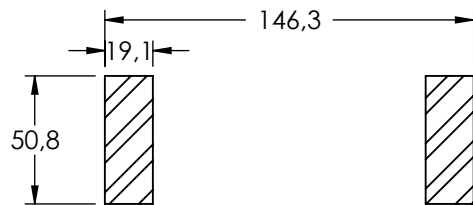
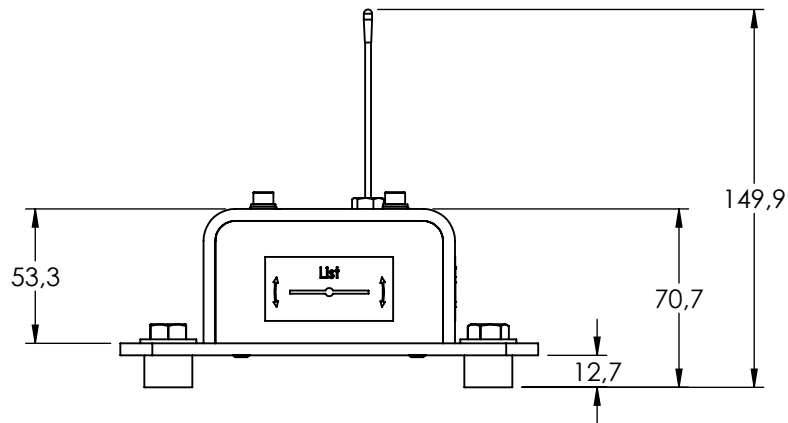
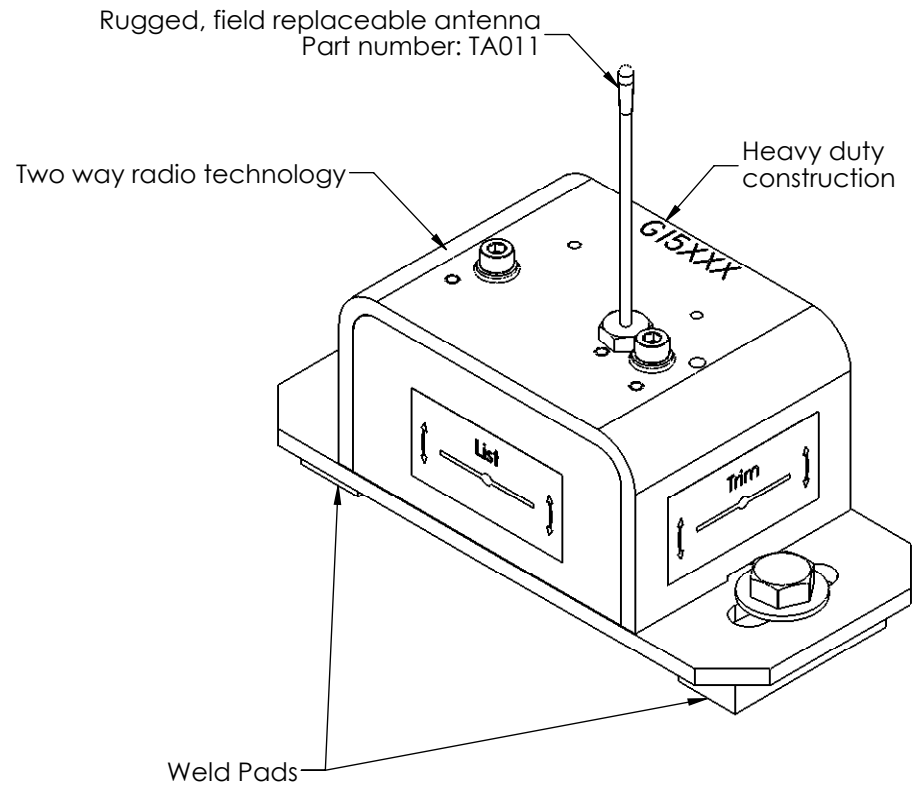
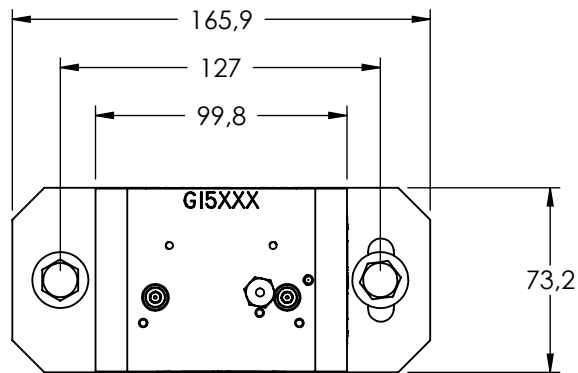

Weld pads footprint

Range	-15° to 15°
Resolution	+/- 0.1°
Repeatability	+/- 0.2°
Accuracy	+/- 0.5° max. (typical +/- 0.2°)
Battery	1 "D-Cell" Lithium, or alkaline
Estimated Battery Life*	Lithium: 2 years, Alkaline: 8 months
Operating temperature	-35 to +85 °C
Radio Frequency Band	900 MHz standard - European Community's 868 MHz as an option
Radio Power	15 dBm
Material	Stainless Steel
Weight	1.81lb

All dimensions are in mm
The information in this document is subject to change without notice

*Battery life estimated for standard product only, using factory specified batteries correctly installed, operating for 32 hours per week. Individual results may vary with intensity of use, environmental conditions and other factors.

PROPRIETARY AND CONFIDENTIAL

THE INFORMATION CONTAINED IN THIS DRAWING IS THE SOLE PROPERTY OF LOAD SYSTEMS INTERNATIONAL. ANY REPRODUCTION IN PART OR AS A WHOLE WITHOUT THE WRITTEN PERMISSION OF LOAD SYSTEMS INTERNATIONAL IS PROHIBITED.



PART NO: **GS010-03** DWG NO: **DS-GS010-03** REV: **8**

DESCRIPTION: **Wireless List and Trim Angle Sensor**